

**Loud Speaker (Internal Magnet)**

**Model: LIU31R-16H2.0W4**



**ELECTRICAL SPECIFICATIONS**

	Condition	Parameter	Unit
Sound Pressure Level	at 0.1W, 0.1M [at 1.0, 1.2, 1.5, 2.0KHz]	82 ± 3	dB
Impedance	at 1V, 1000Hz	4 ± 15%	Ω
Rated Input Power		2	W
Max Input Power		3	W
Resonant Frequency (Fo)	at 1V	300 ± 20%	Hz
Frequency Range		Fo ~ 20000	Hz
Buzzer & Rattles	not be audible at sine wave between Fo ~ 20KHz	2.82	V
Operating Temperature		-25 ~ 55	°C
Magnet		Nd-Fe-B	
Frame Material		Metal	
Cone Material		Paper	
Weight		15	g

**MECHANICAL DRAWING**

Dimensions in mm

Tolerance ±0.5mm Except Specified

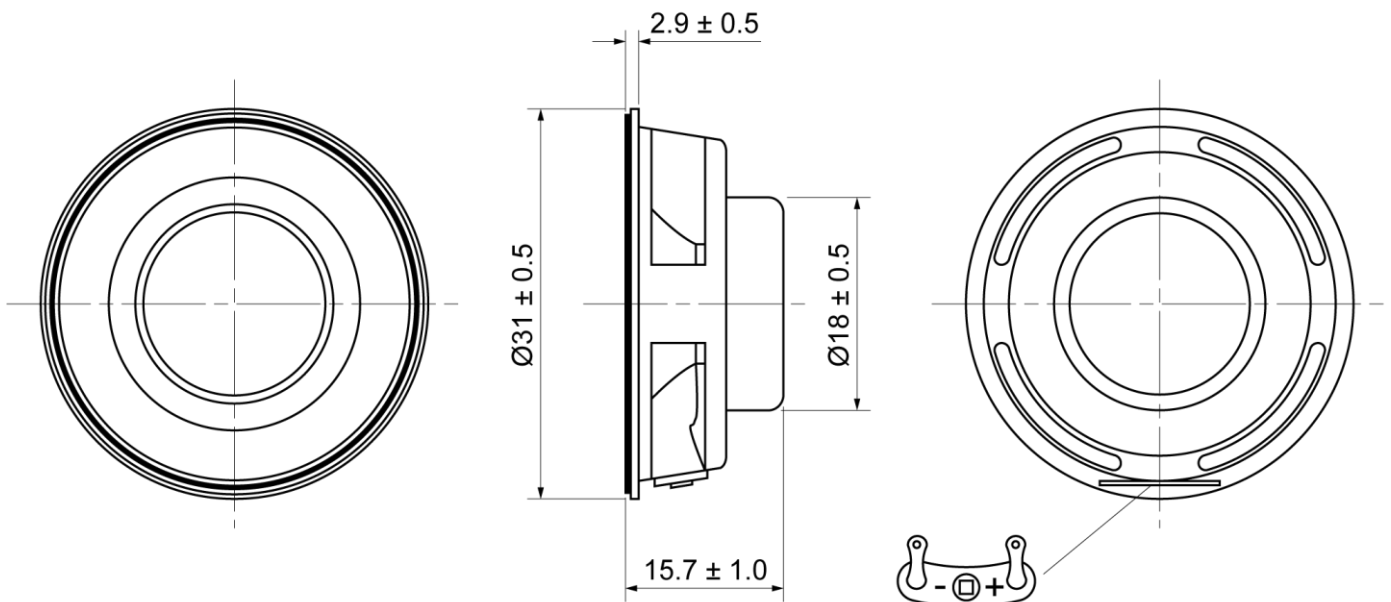

**Loud Speaker (Internal Magnet)**

**Model: LIU31R-16H2.0W4**

**FREQUENCY RESPONSE CURVE**

